

COMPARTMENT DIMENSIONS					
COMPT.	DOOR OPENING	INTERIOR	DIVIDE HEIGHT	UPPER DEPTH	LOWER
L1	30"W x 56"H	32"W x 69"H	27"	14"	25"
L2	68"W x 24"H	75"W x 37"H	N/A	14"	N/A
L3	48"W x 56"H	48"W x 69"H	27"	14"	25"
R1	30"W x 33"H	32"W x 37"H	27"	14"	25"
R2	48"W x 33"H	48"W x 37"H	27"	14"	25"
T1	40"W x 26"H	46"W x 45"H	N/A	25"	25"

GROUND LADDERS & PIKE POLES			
ITEM	DESCRIPTION	MODEL #	QTY
A	24' 2-SEC EXTENSION	PEL-24	1
B	14' ROOF	PRL-14	1
C	10' FOLDING ATTIC	FL-10	1
D	PIKE POLE	-	3

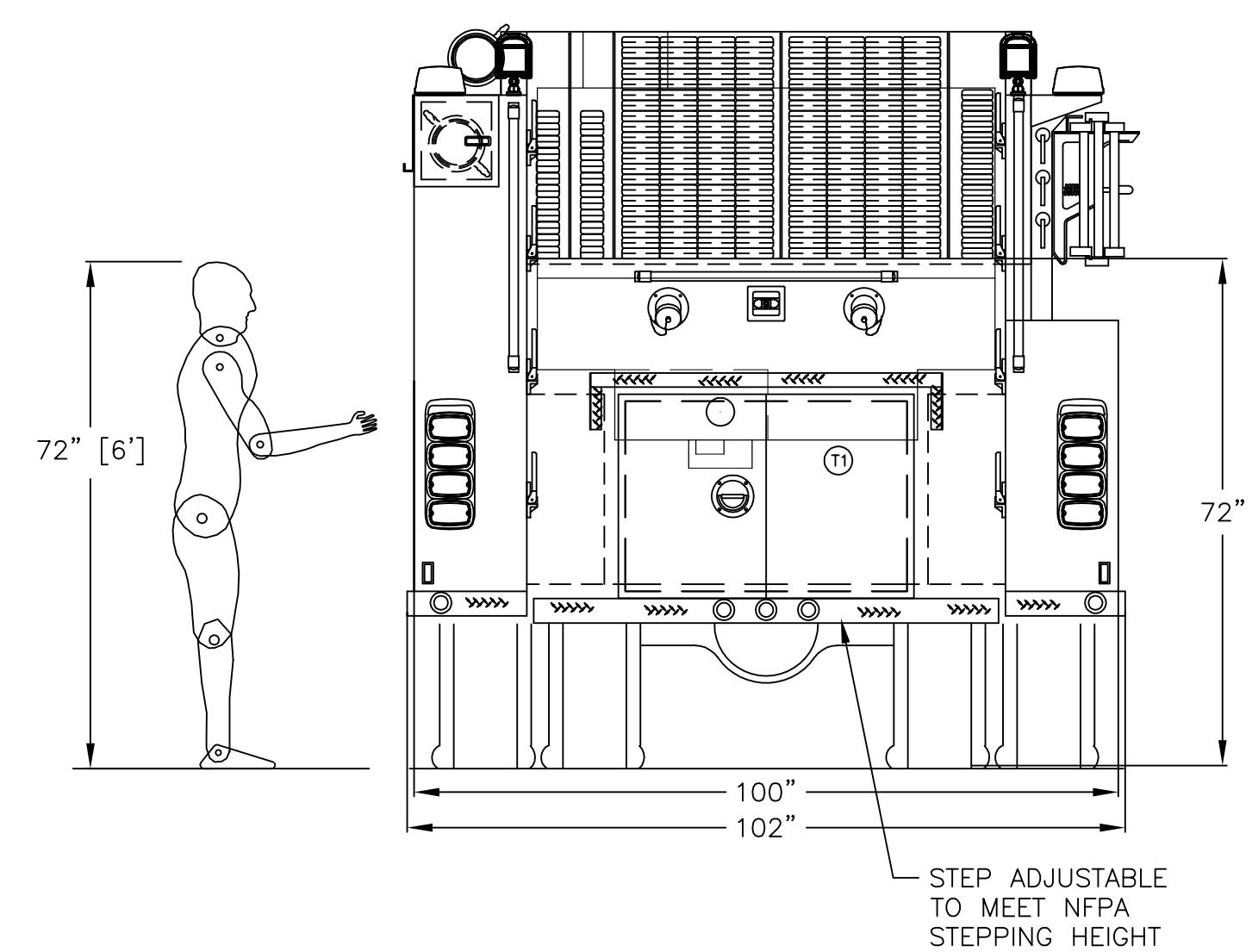
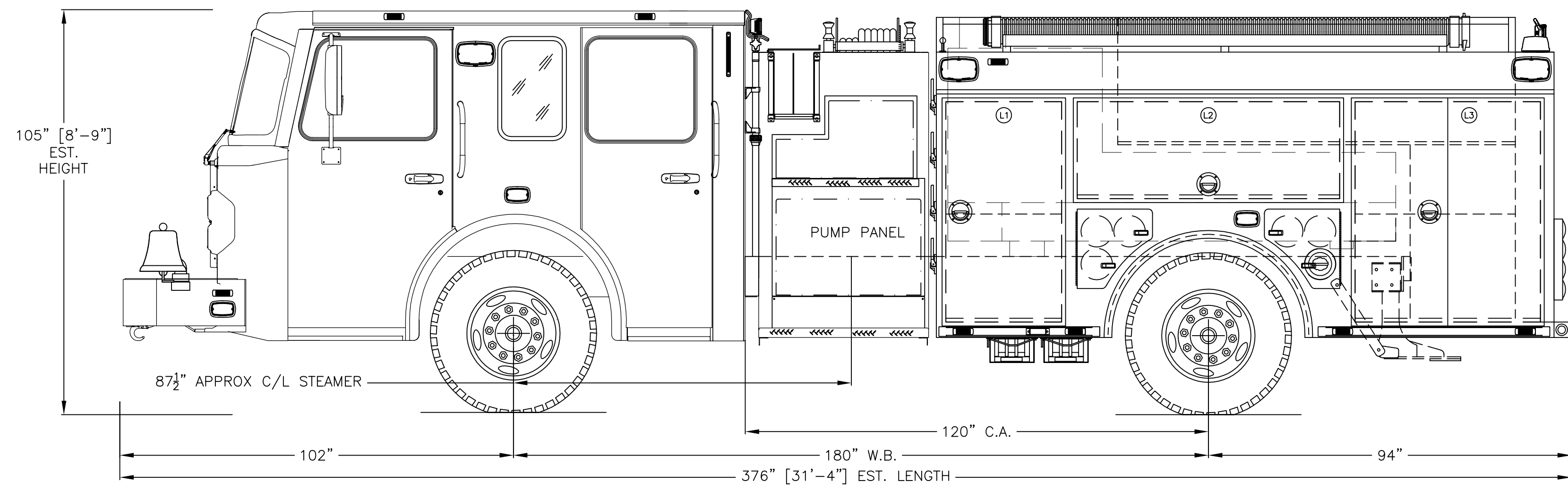

**NOTE:**  
 THIS DRAWING IS THE PROPERTY OF SPARTAN FIRE LLC AND IS TO BE USED ONLY IN REFERENCE TO THE WORK PROPOSED OR CONTRACTED BY SPARTAN FIRE LLC ANY REPRODUCTION IN PART OR IN WHOLE WITHOUT THE WRITTEN PERMISSION OF SPARTAN FIRE LLC IS STRICTLY PROHIBITED.  
 DIMENSIONS SHOWN ARE APPROXIMATE AND ARE SUBJECT TO CHANGE AS MAY BE FOUND NECESSARY DURING CONSTRUCTION. THIS DRAWING MUST BE PLOTTED TO THE PAPER SIZE LISTED IN THE TITLE BLOCK FOR THE LISTED SCALE TO BE VALID.  
 THIS DRAWING IS FOR REFERENCE PURPOSES ONLY. SOME ITEMS MAY OR MAY NOT APPEAR ON THE DRAWING THAT MAY OR MAY NOT BE INCLUDED IN THE SPECIFICATIONS. THE SPECIFICATIONS SHALL BE THE FINAL AUTHORITY TO DETERMINE WHAT IS SUPPLIED ON THE APPARATUS.

REVISION HISTORY			
REV	INT.	DATE	DESCRIPTION
01	CL	8/18/17	LAYOUT FROM CLONE OF 18630-07, NEW OAH
02	Brod	05/25/18	CHANGE TO GLADIATOR, DROP CAB, NEW AIR RIDE, SHORT 50 GALLON FUEL TANK, 105" OAH
03	Brod	07/16/20	CHANGE RR SUSPENSION, WATER TANK CAP, PUMP TO SINGLE STAGE, UPPER ZONE A LTS, WHL CHOCKS
04	Brod	8/31/20	ADD WARN/SCN LTS, RELOCATE HARD HOSE, DELETE SIDE STEPS

**PROPOSAL**

CHASSIS: SPARTAN GLADIATOR EMFD FLAT ROOF W/DROP CAB  
 ENGINE: CUMMINS L9 450HP WITH ALLISON 3000 EVS  
 PUMP: WATEROUS CMUC20 1500 GPM  
 WATER TANK: 750 U.S. GAL  
 FOAM CELL: N/A  
 BODY MATERIAL: 1/8" ALUMINUM  
 HOSE BED: 115 CUBIC FEET  
 GENERATOR: N/A  
 COMPARTMENTS: 112 CUBIC FEET



TOWN OF BRISTOL BRISTOL, RI SIDE MOUNT PUMPER			
MODEL:	NEFEA		
DEALERSHIP:	NEFEA		
SCALE: 1/2" = 1'	DRAWN BY: CL	DATE: 08/31/20	
SIZE: 24" X 36"	DRAWING NO: 18630	REV: 04	
SHEET: 1 OF 1			